

SMART EV BMS WITH REAL-TIME MONITORING AND ACTIVE CELL BALANCING

K Uma Rani¹ | M. Ruchitha² | G. Sindhu³ | V. Mehak⁴ | T. Mounika⁵

1 Assistant Professor, EEE Department, Bhoj Reddy Engineering College for Women, Hyderabad, Telangana, India.

**2, 3,4&5 Undergraduate Students, EEE Department, Bhoj Reddy Engineering College for Women, Hyderabad, Telangana, India.*

Abstract:

A Smart Electric Vehicle (EV) Battery Management System (BMS) is essential for ensuring safe and efficient battery operation. The proposed system integrates real-time monitoring, charge monitoring, fire protection, and active cell balancing to improve battery performance and lifespan. It continuously monitors cell voltage, temperature, and charging status to prevent over-voltage, under-voltage, and thermal risks. Active cell balancing maintains uniform voltage distribution across cells, enhancing efficiency and stability. Additionally, IoT integration using ESP8266 and ThingSpeak enables real-time remote monitoring and data analysis. The system improves safety, reliability, and energy utilization, making it suitable for modern EV applications.

Keywords: BMS, Real-Time Monitoring, Charge Monitoring, Active Cell Balancing, Fire Protection, ESP8266, ThingSpeak, Electric Vehicles.

1. INTRODUCTION

An Electric Vehicle (EV) Battery Management System (BMS) ensures safe and efficient battery operation. It monitors key parameters like voltage, current, and temperature. Conventional systems lack real-time monitoring and advanced safety features, leading to reduced performance. To overcome this, a smart BMS with real-time monitoring is developed for better reliability and efficiency.

The system integrates charge monitoring, fire protection, and active cell balancing. It ensures safe charging, maintains equal cell voltage, and prevents thermal risks. IoT technology using ESP8266 and ThingSpeak enables remote monitoring. Overall, it improves battery safety, lifespan, and performance in EV applications.

Several Authors Researched on Wireless Notice Board Systems

K. Shimitzu, N. Shirai, and M. Nihei, "On-board battery management system with SOC indicator," *Proc. Int. Electric Vehicle Symp. (EVS)*, vol. 2, pp. 99–104, proposes an on-board BMS with integrated SOC indication that enables real-time monitoring of battery performance, emphasizes accurate SOC estimation for efficient operation, and enhances overall battery safety, reliability, and system efficiency. [1].

Gregory L. Plett, this paper presents advanced techniques for accurate estimation of State of Charge (SOC) and State of Health (SOH), enabling reliable real-time monitoring. His methods are widely used in modern EV battery systems [2].

Jian Cao and Ali Emadi, this paper discusses advanced battery control strategies and energy management systems, including cell balancing techniques for improved efficiency. Their work contributes to hybrid energy storage system design [3].

Sabhavath Anil and Shyam Babu (2024), this paper develops an IoT-based BMS that enables real-time monitoring of SOC, voltage, and temperature, helping to prevent overcharging and thermal risks. The system uses wireless communication for remote access and data visualization [4].

Sourajit Dasgupta et al. (2025), this work proposes a smart BMS with real-time monitoring, active cell balancing, and thermal protection to enhance battery efficiency and lifespan. It improves performance by maintaining uniform charge distribution across cells [5].

Davide Andrea, this work explains the design and implementation of Battery Management Systems with emphasis on monitoring, protection, and cell balancing for improved battery performance. It serves as a foundational guide for large lithium-ion battery pack design [6].

Sai Krishna Mulpuri, Bikash Sah, and Praveen Kumar (2025), this paper introduces an IoT and cloud-based BMS that enables real-time remote monitoring and improves system safety and scalability. It allows users to track battery parameters from anywhere [7].

Davide Andrea, this work explains the design and implementation of Battery Management Systems with emphasis on monitoring, protection, and cell balancing for improved battery performance. It serves as a foundational guide for large lithium-ion battery pack design [8].

T. M. Bandhauer, S. Garimella, and T. F. Fuller, this work highlights thermal management and safety issues in lithium-ion batteries, helping to prevent overheating and fire hazards. It provides critical insights into battery cooling techniques [9].

José Gabriel O. Pinto, João P. D. Miranda, and Luís A. M. Barros, this project presents a modular BMS with active cell balancing using DC–DC converters for improved efficiency and fault tolerance. The design supports scalable battery systems [10]

The proposed Smart EV Battery Management System (BMS) is designed to ensure safe, efficient, and reliable battery operation by integrating real-time monitoring, charge monitoring, and advanced protection mechanisms. It continuously tracks key parameters such as voltage, temperature, SOC, and SOH to prevent overcharging, deep discharge, and thermal risks. Active cell balancing is implemented to maintain uniform voltage across all cells, improving battery lifespan and performance. The system also includes fire protection and fault detection features to enhance safety under abnormal conditions. IoT integration using ESP8266 and ThingSpeak enables real-time remote monitoring and data analysis.

2. BLOCK DIAGRAM

Smart EV BMS with real time monitoring and Active cell Balancing system begins with a step-down transformer that reduces the high AC voltage to a suitable low voltage level for the circuit. This power is then supplied to the charging circuit, which regulates and distributes energy to the battery packs. The system consists of three 12V battery packs connected through relays (Relay-1, Relay-2, Relay-3). These relays control the charging and discharging process and also enable active cell balancing to maintain uniform voltage across all battery packs. Each battery pack is connected to a voltage sensor that continuously monitors its voltage levels. The analog signals from these sensors are fed into an Analog-to-Digital Converter (ADC), which converts them into digital signals. A PIC microcontroller acts as the main control unit, processing the data and ensuring proper battery management. An LM35 temperature sensor is used to monitor battery temperature and prevent overheating and fire hazards.

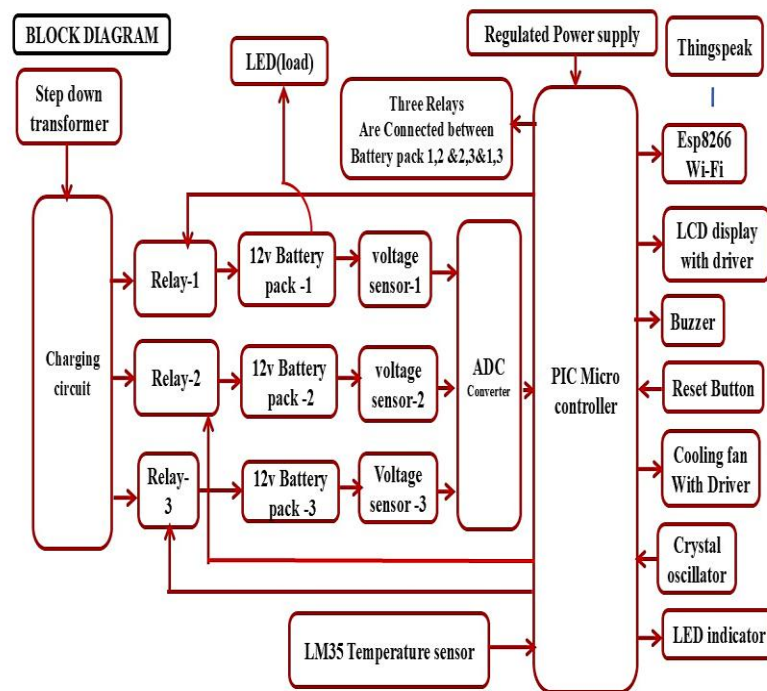

Figure 1. Block Diagram

For safety and monitoring, the system includes a buzzer, cooling fan, and LED indicators that activate during abnormal conditions. An LCD display provides real-time information about battery status. Additionally, the ESP8266 Wi-Fi module transmits data to the ThingSpeak platform for remote monitoring and analysis. Supporting components such as the regulated power supply, crystal oscillator, and reset button ensure stable and efficient system operation.

3. HARDWARE MODULE

The Smart EV Battery Management System (BMS) operates by first reducing high AC voltage using a step-down transformer, followed by a rectifier and regulated power supply.

that provides stable DC voltage to the circuit. The charging system distributes power to three 12V battery packs, which are controlled through relays (Relay-1, Relay-2, Relay-3) to manage charging, discharging, and active cell balancing. Each battery pack is continuously monitored using voltage sensors, and the signals are converted from analog to digital using an ADC. A PIC microcontroller acts as the brain of the system, processing this data to maintain safe operation and balanced voltage levels across all batteries. Additionally, an LM35 temperature sensor monitors heat conditions to prevent overheating and potential fire hazards. For protection and user awareness, the system includes a buzzer, cooling fan, and LED indicators that activate during fault conditions such as overvoltage or high temperature. A 16x2 LCD display provides real-time battery status, while the ESP8266 Wi-Fi module enables remote monitoring by sending data to the ThingSpeak platform. Supporting components like the crystal oscillator and reset circuit ensure stable and reliable performance. The hardware module build for Smart EV BMS with Real time monitoring and Active cell Balancing is shown in the Figure 2.

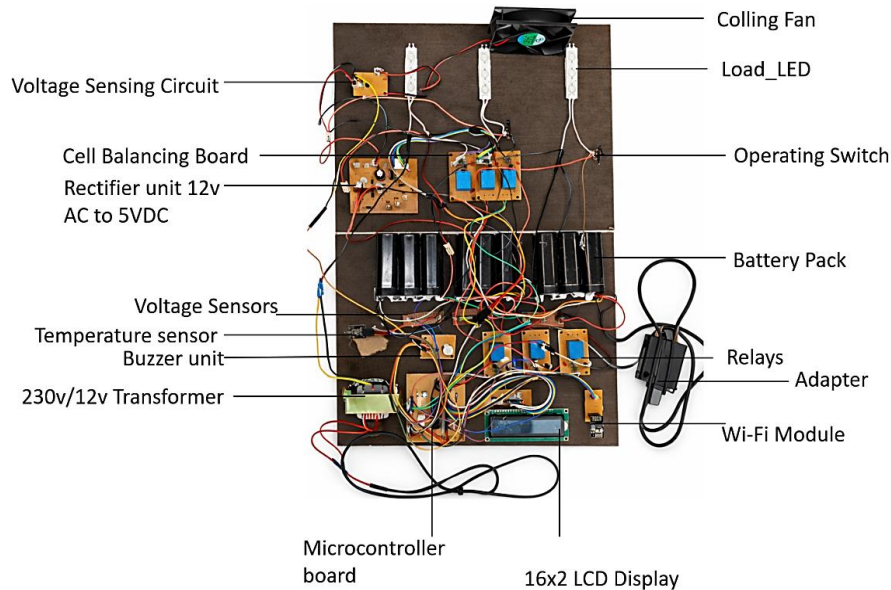

Figure 2. Hard ware Module

Overall, this integrated system enhances battery safety, efficiency, and lifespan through continuous monitoring, automated control, and active cell balancing.

4. TESTING AND RESULTS

4.1 TESTING UNDER DIFFERENT CONDITIONS

4.1.1 Case 1: Nominal Stage (No Load / Normal Condition)

The nominal stage refers to the condition where the battery is connected to the BMS but no external load is applied. In this stage, the system operates in an idle condition.



Figure 3. 16x1 LCD Display of parameters under no load condition

Real-Time Parameter Monitoring of Battery Pack-1 Using ThingSpeak

The system operates in a stable condition without any load, and all parameters remain constant with no power consumption

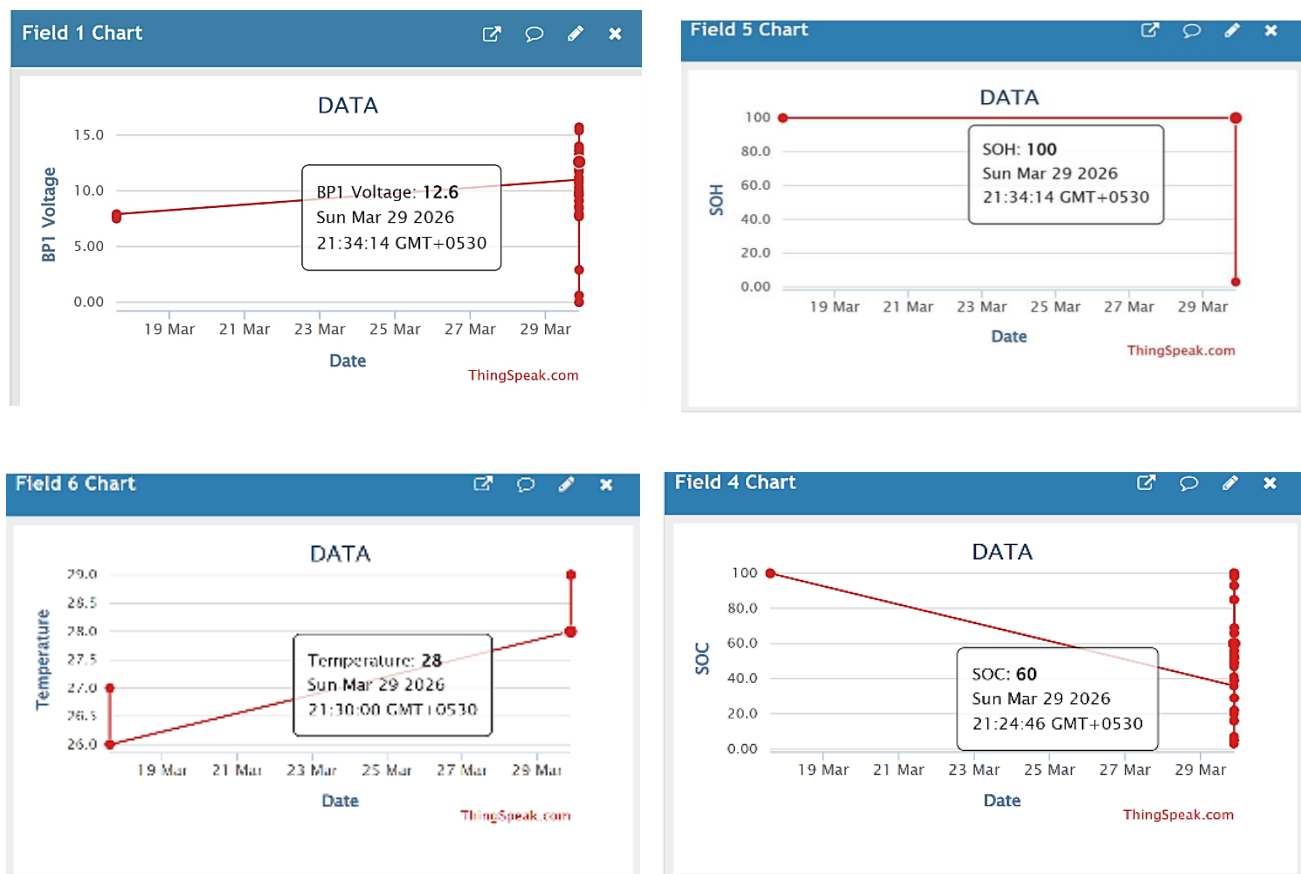

Figure 4 . Real time monitoring graphical representation of BP1 Voltage , SOH,SOC& Temperature at no load condition

4.1.2 Case-2 Loaded Stage (With Load Connected)

In this case, , Load 1 is connected to the system using a 5 V supply. The connected load drives a 5 V light, which is observed to glow (blowing). This indicates active power delivery from the battery pack under load conditions. Under load conditions with a 5 V load connected, Battery Pack 1 exhibits a noticeable performance drop, with terminal voltage decreasing to 9.6 V and the State of Charge (SOC) reducing to 22%.

This reflects the impact of increased power demand during operation and highlights the importance of continuous monitoring of voltage and SOC for safe and efficient battery management.



Figure 5. 16x1 LCD Display of parameters under loaded condition

Battery Pack 1 is monitored in real time using ThingSpeak, displaying voltage and SOC as graphs. Under load, a drop to 9.6 V and SOC to 22% is observed. This helps in analyzing performance and ensuring proper BMS operation

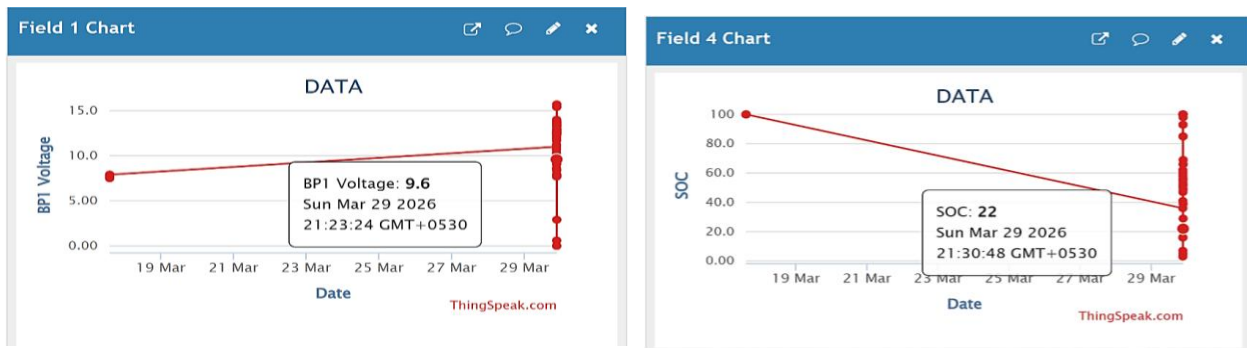

Figure 4 . Real time monitoring graphical representation of BP1 Voltage &SOC at loaded condition

4.1.3 Case-3 Active Cell Balancing Stage

In the active cell balancing stage, the threshold voltage is set to 7 V. When the voltage of Battery Pack 1 falls below this threshold value, it is identified as an under-voltage condition, and the balancing process is initiated to redistribute energy from higher-voltage packs to Battery Pack 1.

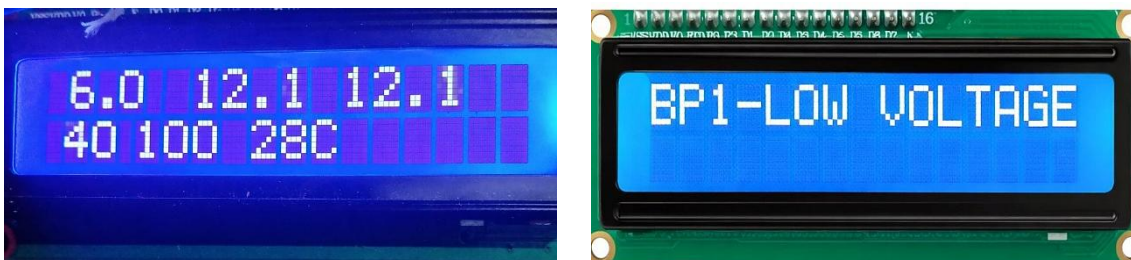

Figure 5. BP1 Voltage is less than threshold voltage(7Volts) & Indication Battery pack 1 is Low Voltage

BP1 – LOW VOLTAGE” is displayed when Battery Pack 1 (BP1) voltage drops to 6 V, which is below the predefined threshold value of 7 V. This condition indicates that BP1 is in a low state of charge and is unable to maintain the required operating voltage



Figure 6. Battery is connected between BP3 to BP1 for Active cell Balancing

The BMS performs active cell balancing by transferring energy from Battery Pack 3 (stronger) to Battery Pack 1 (weaker) when BP1 voltage drops below the threshold (e.g., 6 V). Using relays or MOSFETs, it connects the packs to restore BP1 voltage and maintain uniform voltage levels across the system



Figure 7. Active Cell Balancing

After active cell balancing, all battery pack voltages become nearly equal (12.1–12.4 V), confirming effective energy transfer from higher-voltage packs to the previously weak BP1. The system shows stable conditions with SOC around 55% and temperature near 28°C. This ensures uniform performance, improved efficiency, and safe battery operation, validating the BMS balancing technique.

4.2 RESULTS

The table illustrates the performance of battery packs across different stages of the Battery Management System. In the nominal condition, all packs operate in a healthy state with balanced voltage, high SOC, and normal temperature. Under loaded conditions, BP1 shows a significant voltage drop to 9.6 V and reduced SOC, indicating discharge, along with a slight temperature rise. During active cell balancing, energy is transferred from stronger packs (BP2 and BP3) to the weaker BP1, restoring voltage and equalizing SOC levels. In charging mode, all battery packs receive stable voltage and current, ensuring proper and uniform charging. In the fire protection stage, BP1 temperature increases to 45°C, triggering an alert, after which the system disconnects the load to ensure safety and prevent damage.

Table 1 Performance Analysis of EV BMS under Different Conditions

Stage	Parameters	BP1	BP2	BP3	Remarks
Nominal condition	Voltage(v)	12.6	12.4	12.1	All packs are in healthy condition
	SOC%	95	96	95	Fully charged
	Temperature	28	30	30	Normal range
	SOH%	97	100	99	Good health
Loaded condition	Voltage(v)	9.6	12.6	12.6	Pack 1 under load drops
	SOC%	22	80	80	Pack 1 discharging
	Temperature	29	29	29	Slight rise due to load
	SOH%	90	100	98	Discharging
Active Cell Balancing	Voltage(v)	6	12.6	12.5	Balance output achieved
	SOC%	80	81	80	Equalized SOC
	Balancing status	Active	Active	Active	Threshold set at 7v
Charging mode	Charging voltage(v)	12.1	12.4	12.5	Charger working properly
	Charging current(A)	2	2	2	Stable charging
	Charger status	ON	ON	ON	Monitoring active
Fire Protection System	Temperature	45	30	30	Pack 1 overheating
	Fire alert status	Activated	Safe	Safe	Alarm triggered
	System action	Load Disconnected	Normal	Normal	Protection ensured

5. CONCLUSION

The Smart EV Battery Management System with real-time monitoring and active cell balancing successfully demonstrates safe and efficient battery operation. The system effectively monitors key parameters such as voltage, State of Charge (SOC), temperature, and State of Health (SOH), enabling continuous performance analysis. Under varying conditions like load, charging, and fault scenarios, the BMS responds appropriately by maintaining stability and protecting the battery packs. The implementation of active cell balancing ensures uniform voltage distribution by transferring energy from stronger to weaker cells, thereby improving overall efficiency and battery lifespan. Additionally, the fire protection mechanism enhances safety by detecting overheating conditions and disconnecting the load. Overall, the proposed system proves to be reliable, efficient, and suitable for electric vehicle applications.

ACKNOWLEDGMENT

The authors are thankful to the officials of Department of Electrical and Electronics Engineering, Bhoj Reddy Engineering College for Women, Hyderabad, India, for providing facilities required to carry out this work.

REFERENCES

1. K. Shimitzu, N. Shirai, and M. Nihei, "On-board battery management system with SOC indicator," Proc. Int. Electric Vehicle Symp. (EVS), vol. 2, pp. 99–104, 1996.
2. G. L. Plett, "Extended Kalman filtering for battery management systems," *Journal of Power Sources*, vol. 134, no. 2, pp. 252–261, 2004.
3. J. Cao and A. Emadi, "A new battery/ultracapacitor hybrid energy storage system for electric, hybrid, and plug-in hybrid electric vehicles," *IEEE Transactions on Power Electronics*, vol. 27, no. 1, pp. 122–132, 2009.
4. D. Andrea, "Battery Management Systems: Design and Implementation," Artech House Publishers, 2010.
5. T. M. Bandhauer, S. Garimella, and T. F. Fuller, "A critical review of thermal issues in lithium-ion batteries," *Journal of the Electrochemical Society*, vol. 158, no. 3, pp. R1–R25, 2011.
6. X. Hu, F. Sun, and Y. Zou, "Online estimation of lithium-ion battery state of charge using adaptive extended Kalman filter," *Applied Energy*, vol. 89, no. 1, pp. 413–420, 2012.
7. J. G. O. Pinto, J. P. D. Miranda, and L. A. M. Barros, "A modular battery management system for electric vehicles," *IEEE Transactions on Industrial Electronics*, vol. 60, no. 9, pp. 4089–4097, 2013.
8. S. Anil and S. Babu, "IoT-based battery management system for real-time monitoring and protection," *International Journal of Engineering Research & Technology (IJERT)*, 2024.
9. S. Dasgupta *et al.*, "Smart battery management system with active cell balancing," *IEEE Access*, 2025.
10. S. K. Mulpuri, B. Sah, and P. Kumar, "IoT and cloud-based battery management system," *International Journal of Electrical and Computer Engineering*, 2025.

